

ACCELERATOR

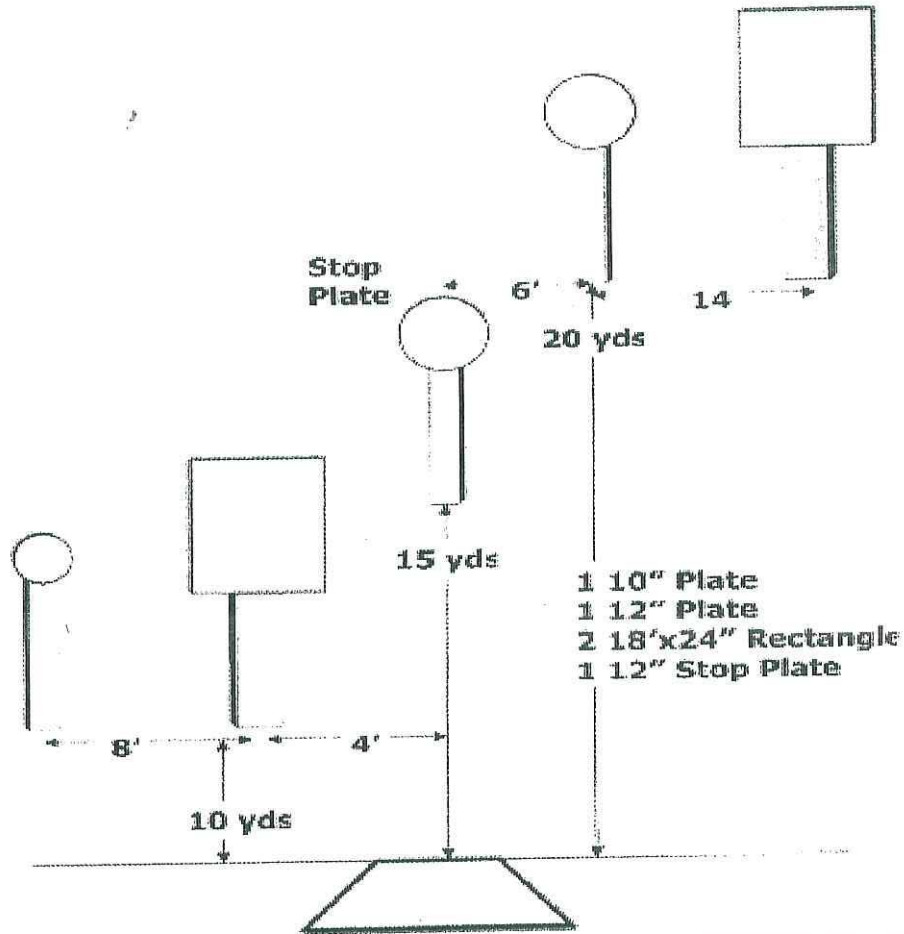

Run	Time	Penalties	Combine
1			4 best times
2			⋮
3			
4			
5			

FIVE TO GO

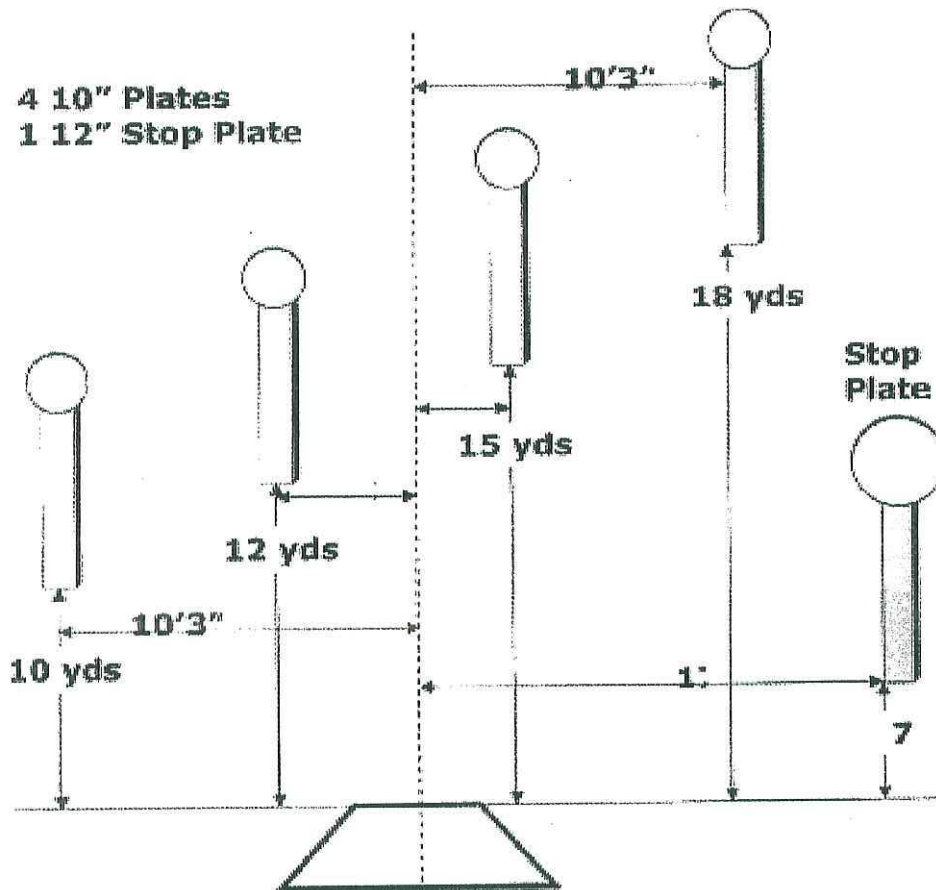

Run	Time	Penalties	Combine
1			4 best times
2			⋮
3			
4			
5			

OUTER LIMITS

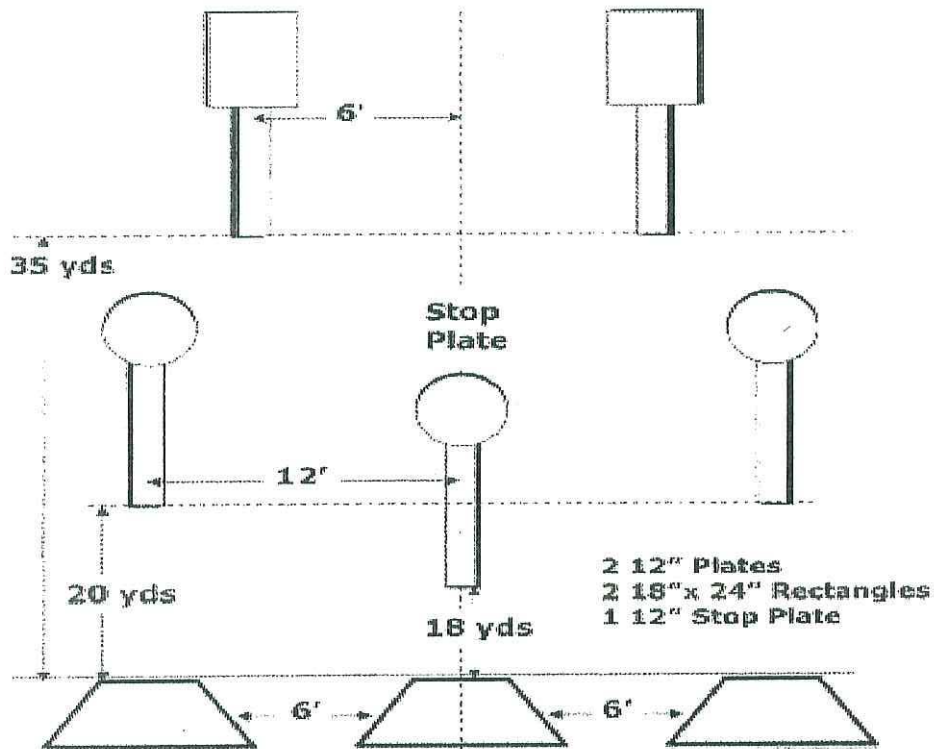

Note: Right handed shooters start from the left hand Box and Left handed shooters from the right hand Box. Shooter must shoot the 2 plates directly in front then move to centre Box and shoot remaining 2 plates and then the Stop Plate.

Run	Time	Penalties	Combine
1			3 best times • •
2			
3			
4			

PENDULUM

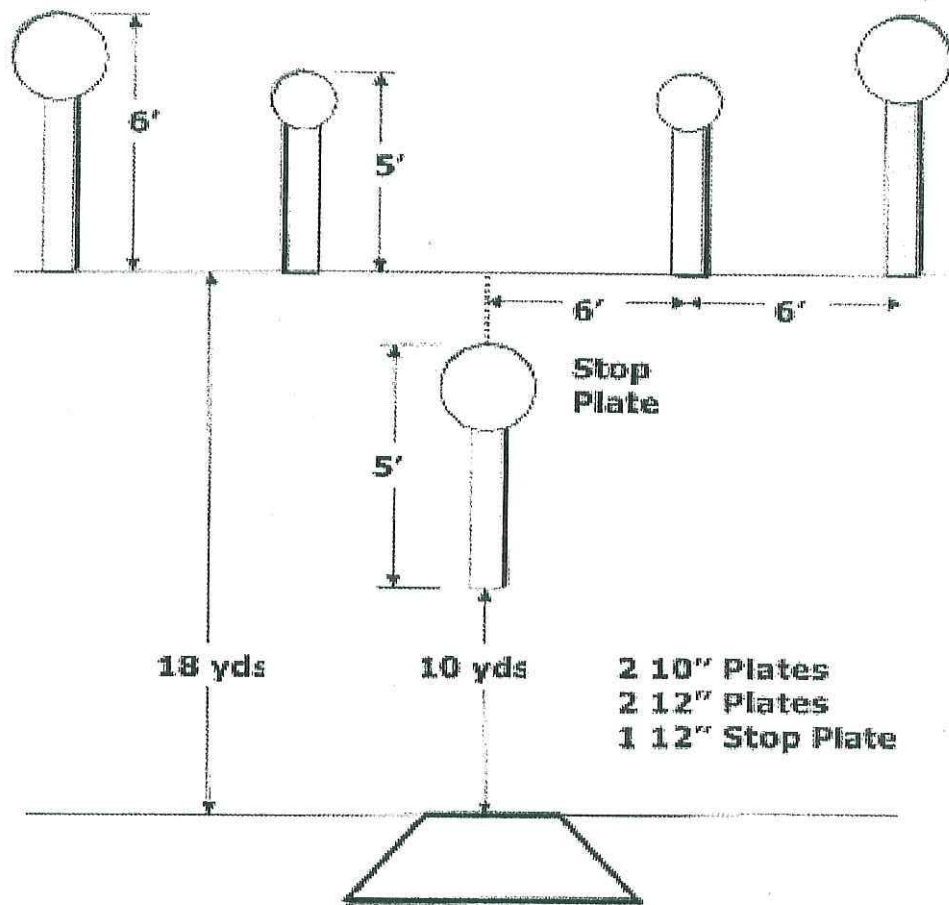

Run	Time	Penalties	Combine
1			4 best times
2			⋮
3			
4			
5			

ROUNDAABOUT

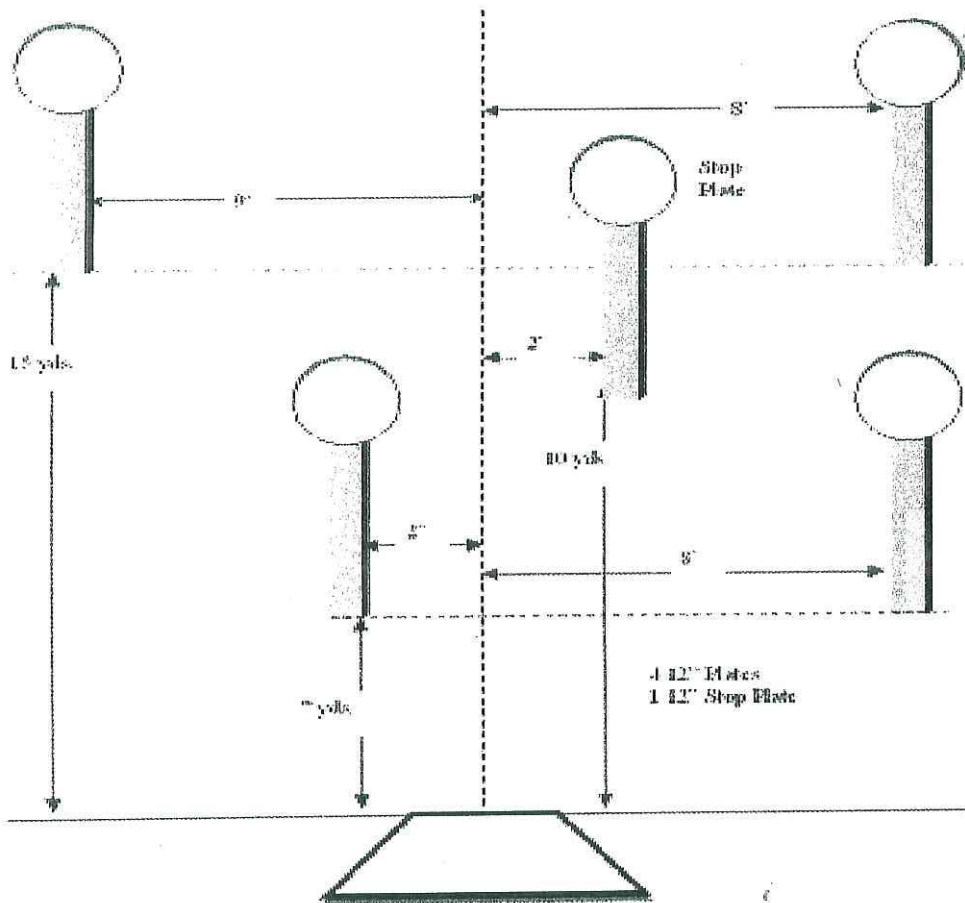

Run	Time	Penalties	Combine
1			4 best times
2			⋮
3			
4			
5			

SHOW DOWN

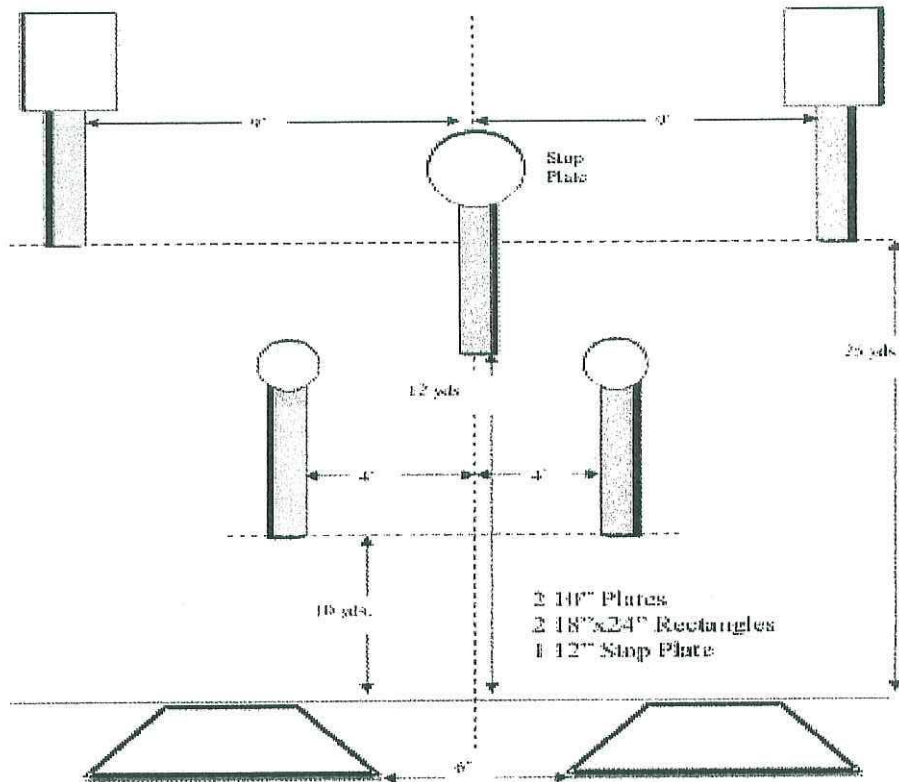

Note: Competitor starts in either Left or Right Box and shoots either 2 or 3 runs from that box, then changes boxes and shoots the remaining 2 or 3 runs. Total number of runs to be shot is 5 with your best 4 being kept.

Run	Time	Penalties	Combine
1			4 best times
2			⋮
3			
4			
5			

SMOKE & HOPE

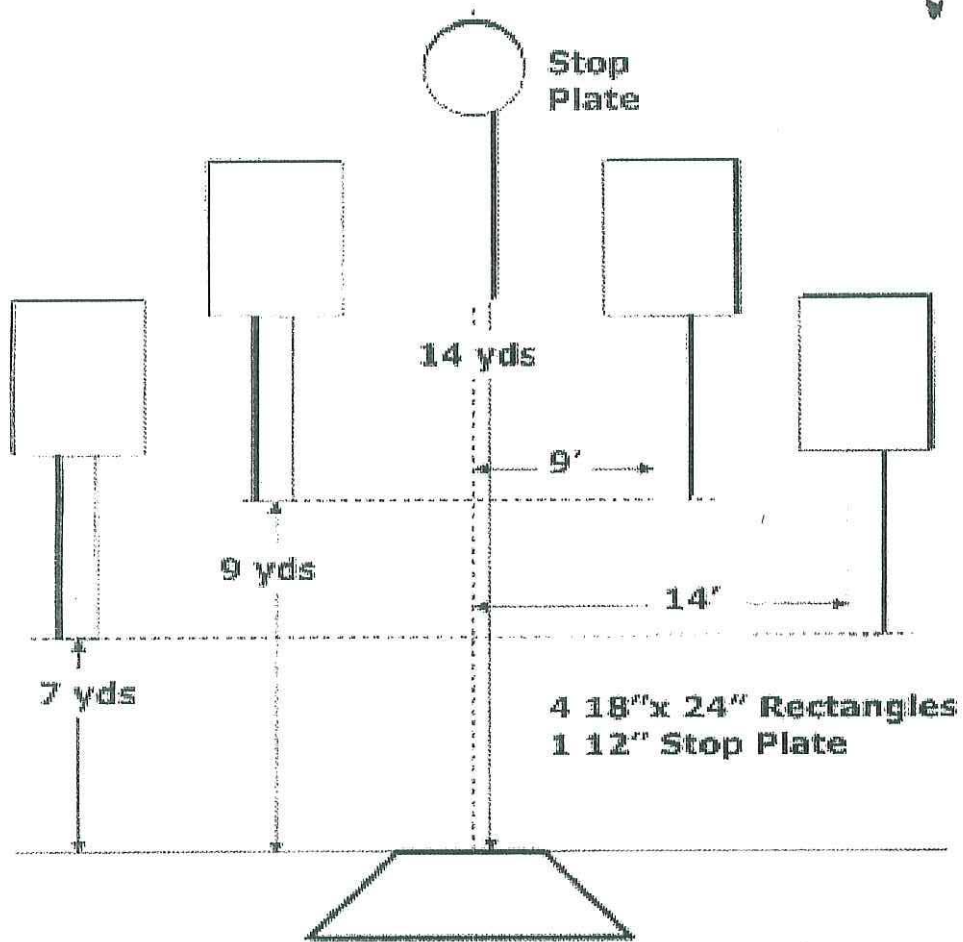

Run	Time	Penalties	Combine
1			4 best times
2			⋮
3			
4			
5			

SPEED OPTION

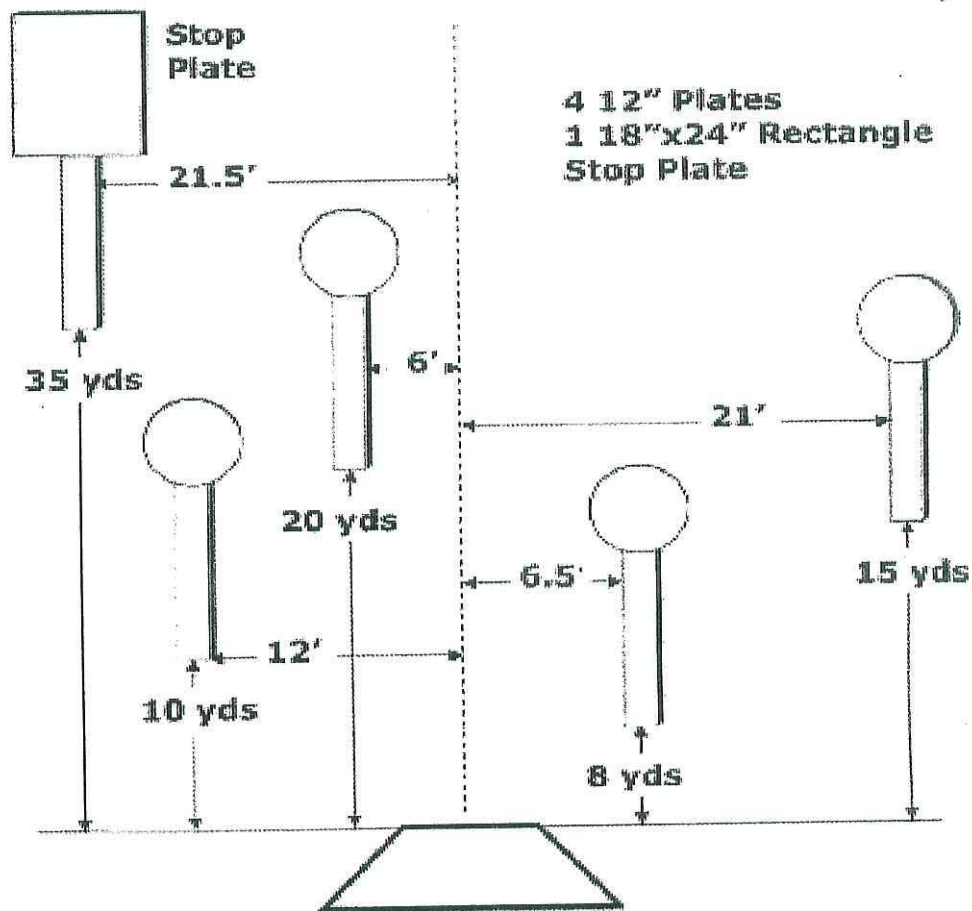

Run	Time	Penalties	Combine
1			4 best times
2			⋮
3			
4			
5			